

# Depth Gage

A standard measuring tool of industry

## Mini Depth Gage SERIES 571

**MeasurLink<sup>®</sup> ENABLED**

Data Management Software by Mitutoyo

- This is a compact depth gage.
- Enables measurement of depth of tire groove.
- Digital display with 0.01 mm resolution enables measurement without misreading.
- ABSOLUTE Digital Depth Gage.
- Allows integration into statistical process control and measurement systems for models with measurement data output connector. (Refer to page A-3.)
- Battery: SR44 (1 pc.), **938882**. For initial operational checks (standard accessory)
- Battery life: Approx. 5 years under normal use.



571-100-20

## SPECIFICATIONS

### Metric

Order No.	Range (mm)	Resolution (mm)	Base (mm)	Maximum permissible error $E_{MPE}$ (mm)*
571-100-20	0 - 25	0.01	60	±0.02

\* Maximum permissible error,  $E_{MPE}$ , is the term (notation) used in JIS B 7518: 2018, revised based on ISO/TR 14253-6: 2012.

### Inch/Metric

Order No.	Range (in)	Resolution (in)	Base (in)	Maximum permissible error $E_{MPE}$ (in)*
571-200-20	0 - 1	0.0005	2.36	±0.001

\* Maximum permissible error,  $E_{MPE}$ , is the term (notation) used in JIS B 7518: 2018, revised based on ISO/TR 14253-6: 2012.

## DIMENSIONS

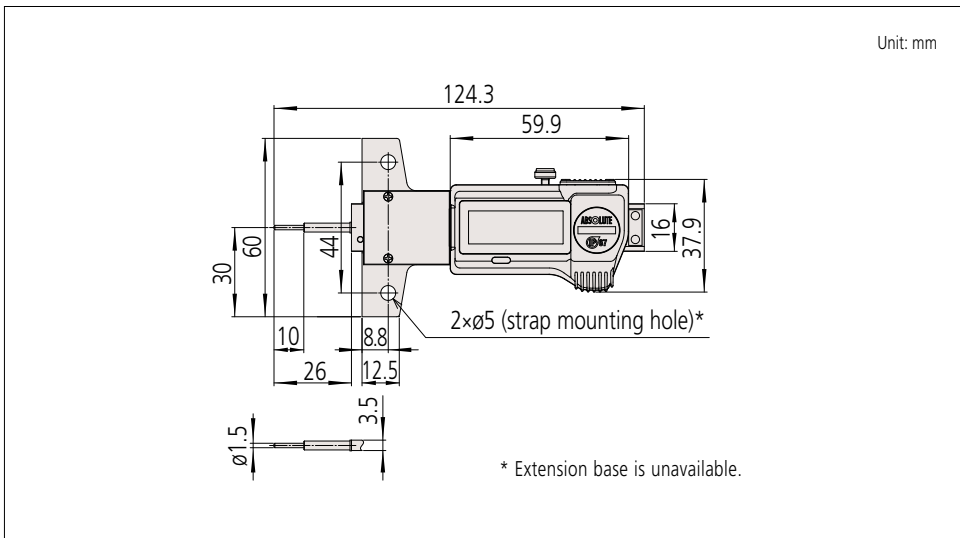

Unit: mm

\* Extension base is unavailable.

**MeasurLink<sup>®</sup> ENABLED**  
Data Management Software by Mitutoyo

Products equipped with the measurement data output function can be connected to the measurement data network system MeasurLink<sup>®</sup> (refer to page A-25 for details).

**ABSOLUTE<sup>™</sup>**

**IP67**



Dust- and Water- Protected

www.tuv.com ID 000045042



## Optional Accessories

For details, refer to page A-21.

- Connection cables for **IT/DP/MUX**
  - 05CZA624**: SPC cable with data button (1 m)
  - 05CZA625**: SPC cable with data button (2 m)
- Note: Optional connecting cable is available only for water-proof type.
- USB Input Tool Direct
  - 06AFM380A**: SPC cable for **USB-ITN-A** (2 m)
- Connecting cables for **U-WAVE-T**
  - 02AZD790A**: SPC cable with data button (160 mm)
  - 02AZE140A**: SPC cable for foot switch

## Wireless Data Output **U-WAVE<sup>™</sup>**

- **U-WAVE-TC: 264-620** (IP67 type)  
**264-621** (Buzzer type)
- **U-WAVE-TCB Transmitter (Mitutoyo Bluetooth<sup>®</sup> U-WAVE)**
  - 264-624** (IP67 type)
  - 264-625** (Buzzer type)
- Refer to page A-10 for details.
- Connecting unit for **U-WAVE-TC/TCB**
  - 02AZF310** (IP67 type)
- Note: IP67 model is water/dust-proofed suitable for the factory floor.  
Buzzer type is not water/dust-proofed.
- Refer to pages A-10 and A-12 for details.